

Student ID: _____

CS457: Computer Networking

Date: 5/8/2007

Name: _____

Instructions:

1. Be sure that you have 8 questions
2. Write your Student ID (email) at the top of every page
3. Be sure to complete the honor statement after you complete the exam
4. This is a closed book exam
5. The seats on both sides of you should be empty
6. State all assumptions and be sure your answers are legible
7. Show all work; the graders will give partial credit
8. Answer each question clearly and to the point; do not define or describe concepts unless asked to do so; assume that the graders are familiar with the concepts

<i>Question</i>	<i>Points</i>	<i>Score</i>
1	15	
2	15	
3	15	
4	10	
5	10	
6	10	
7	15	
8	10	
total	100	

2. TCP Congestion Control

Assuming that no packets are lost, how long will it take TCP to send an object that is 16KB over a link with a RTT of 500milliseconds, a MSS of 1KB, and a rate of 10KB/second when:

- a. TCP is in slow start, CongWin = 1 and Threshold = 10:

RTT 1: segment 1

RTT 2: segments 2, 3

RTT 3: segments 4, 5, 6, 7

Then, segments 8-16 are sent with no delays

Total transmission time = $500 + 500 + 500 + 900 = 2400$ milliseconds

(Also acceptable: Last RTT takes an additional 500 milliseconds, giving 2900 milliseconds)

- b. TCP is in slow start, CongWin = 1 and Threshold = 4:

2400 milliseconds (or 2900 milliseconds)

- c. TCP is in congestion avoidance, CongWin = 5 and Threshold = 5:

All segments are sent with no delays, so this will take 1600 milliseconds (or 2100 milliseconds)

3. MAC Protocols: random access

a. Assume that two nodes want to send a packet and are waiting because the channel is not clear. Once the channel becomes clear (ie. the current packet is finished), what is the probability of collision using CSMA/CD?

100%

b. What is the probability of collision using CSMA/CA? Assume that both nodes will randomly choose to wait 1, 2, 3, ..., or 10 milliseconds.

$1/10 = 10\%$

c. What would be the probability of collision using CSMA/CA if there were three nodes that wanted to send?

$2/10 = 1/5 = 20\%$

4. Link-layer addressing

In the diagram below, assume that host 111.111.111.111 sends a message that it wants to be received at host 222.222.222.222.

a. What is the network-layer address that it must use on the message?

222.222.222.222

b. What is the link-layer address that it must use on the message?

E6-E9-00-17-BB-4B

c. What network-layer and link layer addresses must it use if the message is to be received by 111.111.111.112?

111.111.111.112

and

CC-49-DE-D0-AB-7D

d. How does the node know which link-layer address to use?

It always sends to the default gateway, unless the destination is on the same subnet.

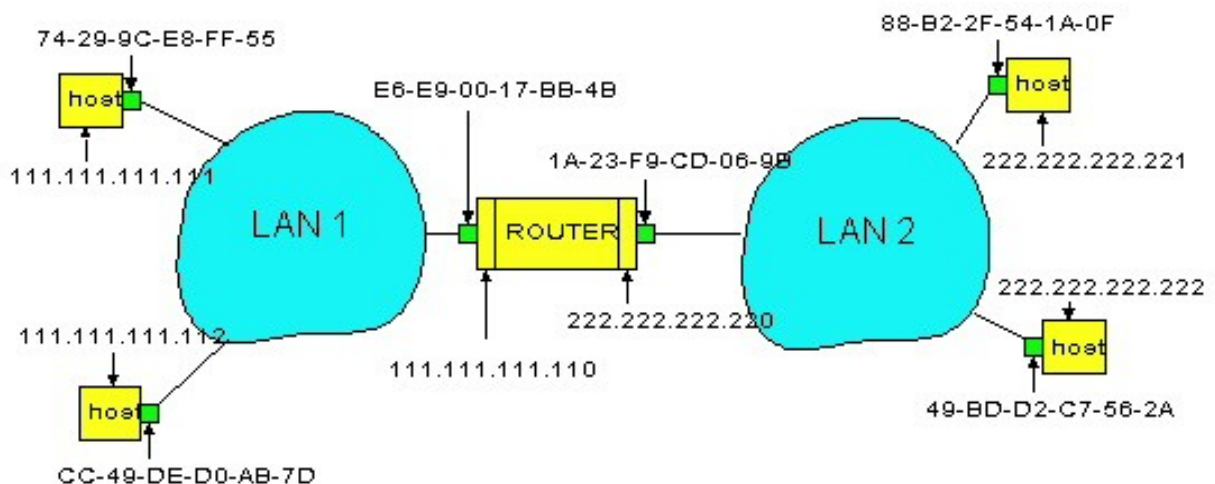

5. Hubs and Switches

In the topology below, assume that all links are 10Mbps. The web server for this organization is quite busy, and serves on average 100 web page requests per second, where each page consists 10 objects in total that are 1KB in size each.

a. How much bandwidth is remaining for communication between nodes A and E in the network? (be careful to convert between bytes and bits, above)

100*10*1KB = 1MBps = 8Mbps. This leaves 2Mbps for A-E communication.

(Also acceptable: 1.2Mbps if work is shown, and 11 objects were used in the calculation)

b. Which of these hubs would you convert to a switch to increase the available bandwidth between A and E?

Hub 1

c. If you needed to support 8Mbps of traffic between the three pairs of nodes (A, E), (D,G), and (B,H), what would the total capacity of the switch need to be (including traffic to/from the web server)?

8*4 = 32Mbps (also acceptable: 32.8Mbps)

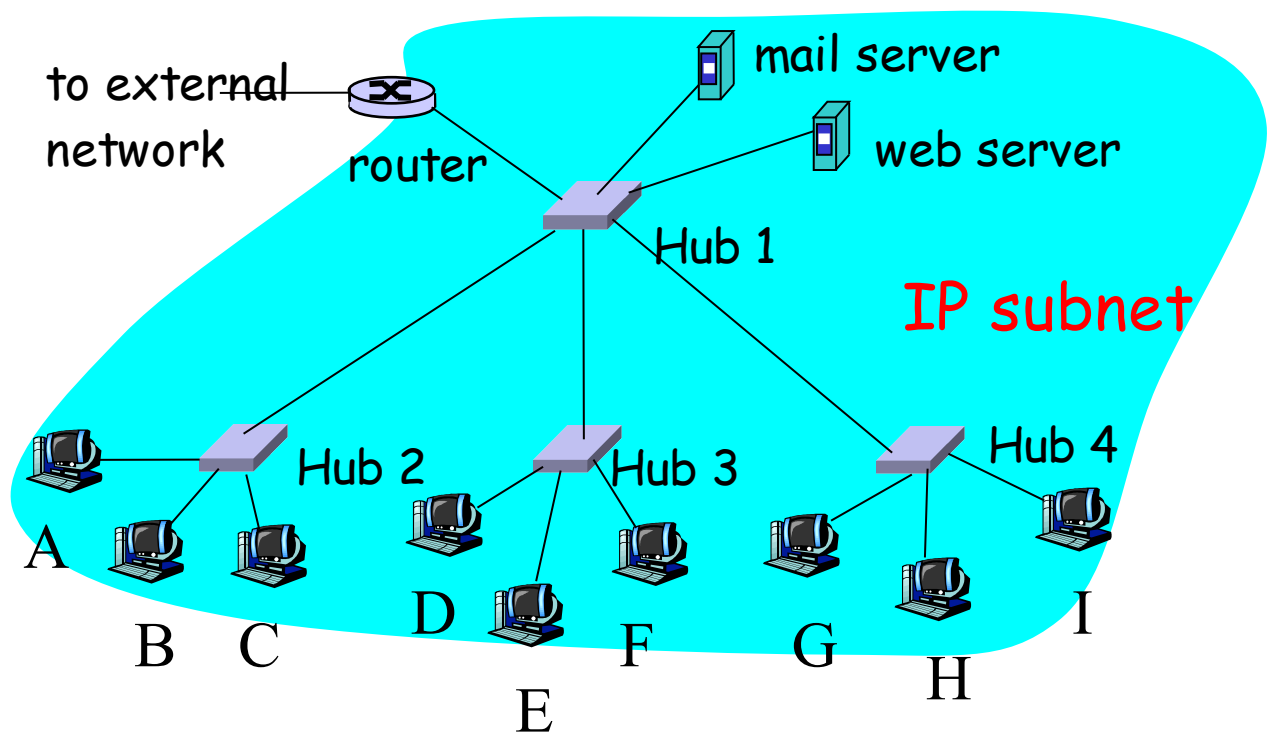

Student ID: _____

d. If you connected each of the three remaining hubs to each other, would that reduce traffic at the switch?

No, it would increase traffic at the switch because it would create a loop of hubs, which causes infinite cycling of packets.

e. If you connected the web server directly to the router, would that reduce traffic at the switch?

Yes, because data from the external router to the web server would never be sent to Hub 1

6. Inside a Router

In the diagram below, packets in the input port queues are shown on the left and the output ports are shown on the right. The packets are labeled with the output port for which they are destined. They also have a number, indicating the order in which they are chosen by the switching fabric. Assume that the switching fabric can transfer up to 3 packets per millisecond total.

a. What is the fastest that this switch can transfer all packets if the switching fabric can write one packet to each output port per millisecond?

5 milliseconds: 1) A1, B1 2) A2, C1 3) A3, B2 4) C2 5) C3

b. What if the switching fabric could write two packets to each output port per millisecond?

3 milliseconds: 1) A1, B1, A2 2) A3, C1, B2 3) C2, C3

c. If this were a memory-based switching fabric, how many transfers would be required over the memory bus? How fast would the memory bus need to be?

To transfer 3 packets per millisecond, the bus in a memory-based switching fabric must be able to transfer 6 packets per millisecond, because each packet must cross the bus two times.

d. If this were a bus-based switching fabric, how many transfers would be required over the bus? How fast would the bus need to be?

To transfer 3 packets per millisecond, the bus in a bus-based switching fabric must be able to transfer 3 packets per millisecond, because each packet must cross the bus one time.

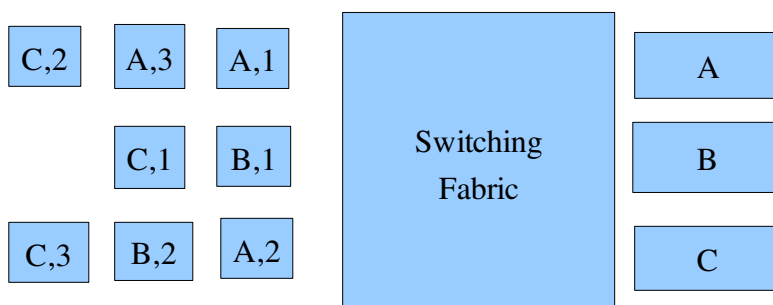

7. Distance Vector vs. Link State Routing

In each of the two networks below, the cost of one link has recently changed.

a. What values were in the routing tables of all three nodes before the link changed? After? Draw your routing tables as follows, listing the next hop node and the total route cost for each destination:

X Table			Y Table			Z Table			
Dest	Next	Cost	Dest	Next	Cost	Dest	Next	Cost	
Y	Z	10	X	Z	10	Y	Y	1	Left Before Right After
Z	Z	9	Z	Z	1	X	X	9	
Y	Y	2	X	X	2	Y	Y	1	Left After Right Before
Z	Y	3	Z	Z	1	X	Y	3	

b. Using the distance vector algorithm, how many distance vector messages are sent out by the nodes in each of these two cases?

In the case on the left, **3** distance vector advertisements are sent:

X sees the link change and updates its distance vector to Y,Y,2 and Z,Y,3

Y sees the link change and updates its distance vector to X,X,2 and Z,Z,1

Z receives an update from Y and updates its distance vector to X,Y,3 and Y,Y,1

Z receives an update from X, and X and Y receive an update from Z, but don't update anything

In the case on the right, **8** distance vector advertisements are sent:

X sees the link change and updates its distance vector to Y,Z,10 and Z,Z,9

(bellman ford will determine that it cannot get to Z through Y)

Y sees the link change and updates its distance vector to X,Z,4 and Z,Z,1

Z receives an update from Y and updates its distance vector to X,Y,5 and Y,Y,1

Y receives an update from Z and updates its distance vector to X,Z,6 and Z,Z,1

Z receives an update from Y and updates its distance vector to X,Y,7 and Y,Y,1

Y receives an update from Z and updates its distance vector to X,Z,8 and Z,Z,1

Z receives an update from Y and updates its distance vector to X,X,9 and Y,Y,1

Y receives an update from Z and updates its distance vector to X,Z,10 and Z,Z,1

All nodes receive their neighbors last updates, but don't update anything themselves

c. Using the link state algorithm, how many link state messages are sent out by the nodes in each of these two cases?

2 message are sent in both cases, by nodes X and Y, respectively. Then, all nodes recalculate all routes internally.

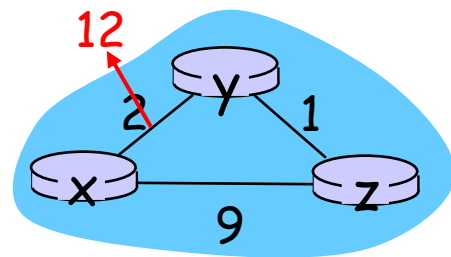
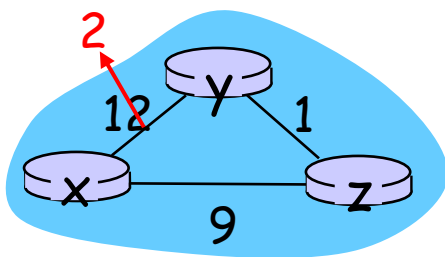

8. Internet Routing

In the diagram below, the three thick dashed lines are inter-AS links and the thinner lines are intra-AS links.

a. Using hot-potato routing, what nodes would be on the route from 2a to 3a?

Hot potato routing sends the message out of the AS as quickly as possible, giving:

2a -> 1b -> 1c -> 3a

b. Using BGP with the AS-PATH attribute, which nodes would be on the route from 2b to 3b?

BGP with AS-path send the message through the smallest number of Ass, giving:

2b -> 2c -> 3a

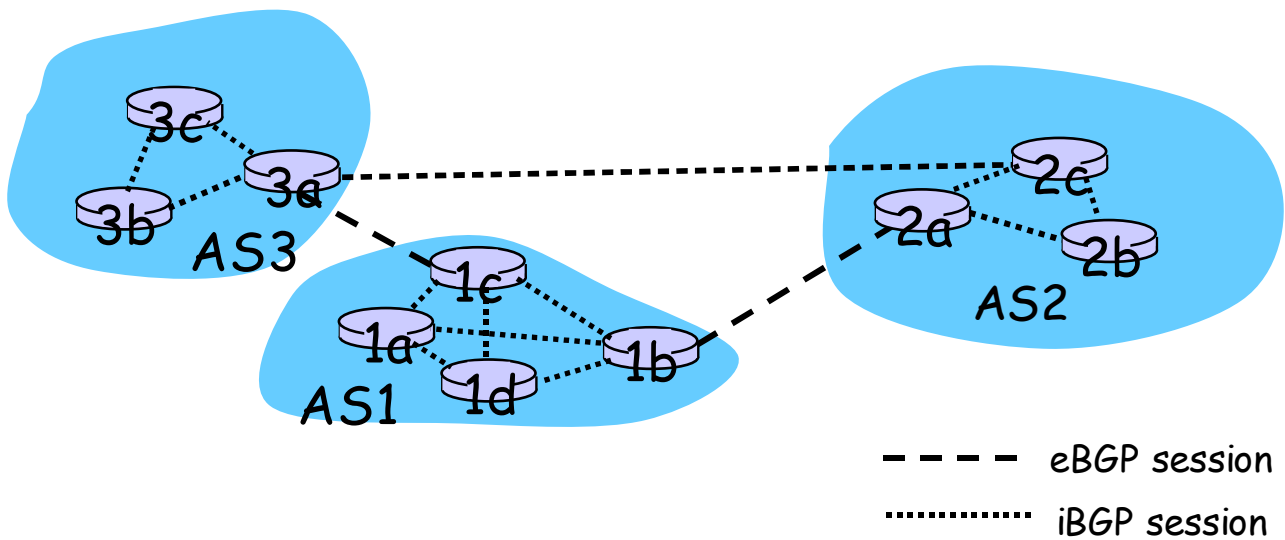

Honor Code

Signature _____