

Virtual Memory 1

last time (1)

exception: control flow not via jump/call/etc.

exceptions: causes

- asynchronous — external event

- traps (system calls, etc.) — deliberately triggered

- faults — something went wrong, maybe recoverable (out of bounds, divide by zero, etc.)

- aborts — something went wrong, not recoverable (main memory is broken)

table of *exception handlers* written by OS

- processor reads table entry

- sets PC to that address

last time (1)

exception: control flow not via jump/call/etc.

exceptions: causes

- asynchronous — external event

- traps (**system calls**, etc.) — deliberately triggered

- faults — something went wrong, maybe recoverable (out of bounds, divide by zero, etc.)

- aborts — something went wrong, not recoverable (main memory is broken)

table of *exception handlers* written by OS

- processor reads table entry

- sets PC to that address

last time (2)

kernel versus user mode

- privileged instructions allowed in kernel mode

- switch to kernel mode when running exception

- switch back to user mode when returning from exception

- user code uses *system calls* to request things only kernel mode can do

privileged operations

- reconfiguring interrupts/exceptions

- talking to I/O devices

- reconfiguring *address spaces* (today's topic)

last time (3)

exception handler operation

- processor saves *old program counter*

- handler saves additional registers it cares about

- handler returns to same program **or elsewhere**

context switching

- exception handler saves current program state

- loads new program into memory, returns to new program

last time (4)

process = illusion of CPU + memory

illusion of CPU through context switching

reasoning about concurrent execution

graph with happens-before arrows

saw examples with fork, but idea is more general

process control *system calls* on Unix-like OSes

fork: create new process by copying current

wait: wait for process to finish, retrieve exit status

exec: load current process into new program

last time (4)

process = illusion of CPU + memory

illusion of CPU through context switching

reasoning about concurrent execution

graph with happens-before arrows

saw examples with fork, but idea is more general

process control *system calls* on Unix-like OSes

fork: create new process by copying current

wait: wait for process to finish, retrieve exit status

exec: load current process into new program

aside on exception terminology

real-world exception terminology is very inconsistent

e.g. sometimes 'exception' means all kinds of exception, sometimes only faults

e.g. sometimes 'interrupts' mean asynchronous events only, sometimes all exceptions

reading CPU manual, textbook, etc. — context clues

program memory

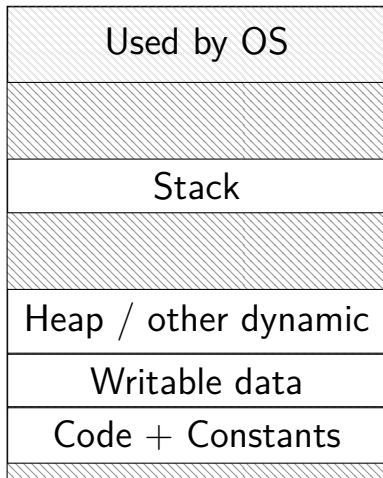

0xFFFF FFFF FFFF FFFF

0xFFFF 8000 0000 0000

0x7F...

0x0000 0000 0040 0000

address spaces

illusion of **dedicated memory**

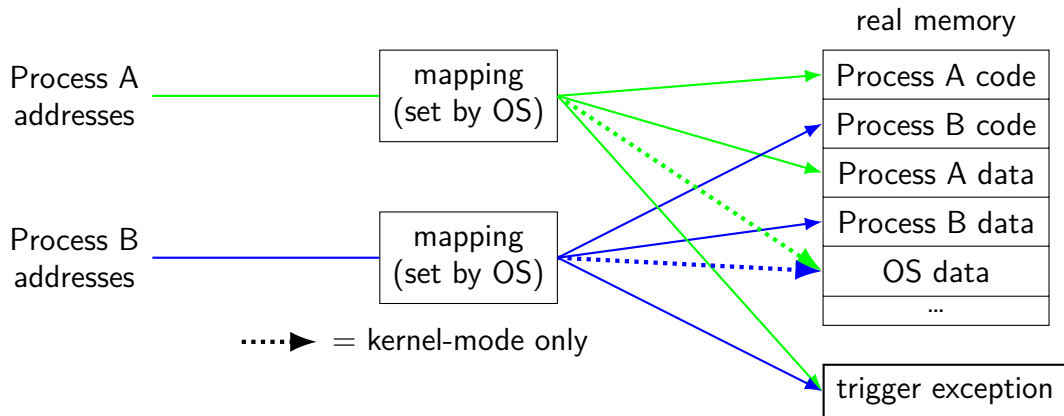

address spaces

illusion of **dedicated memory**

chose one during context switch

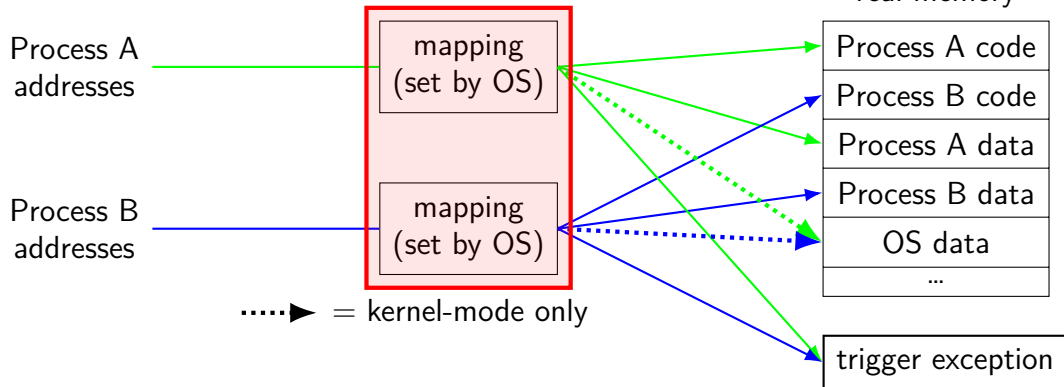

address translation

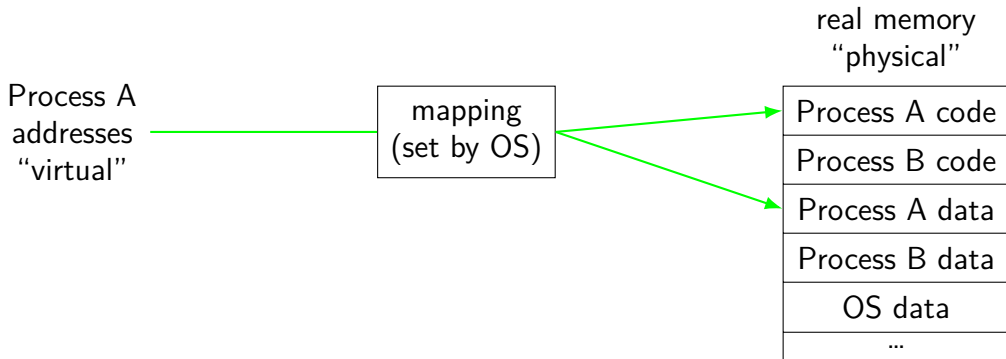

address translation

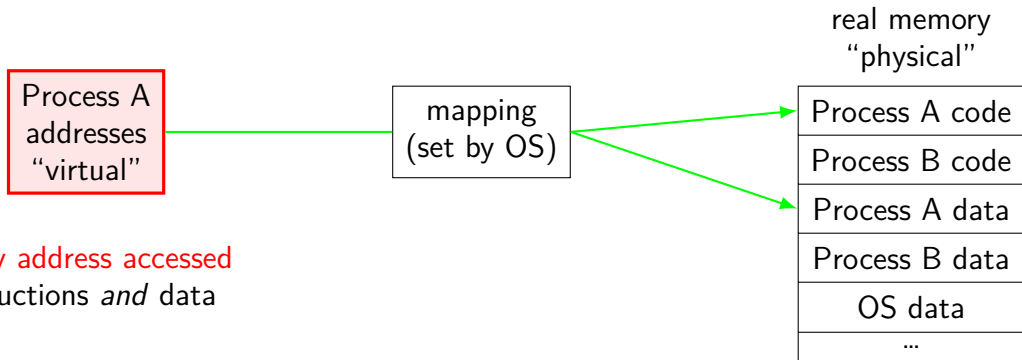

every address accessed
instructions *and* data

address translation

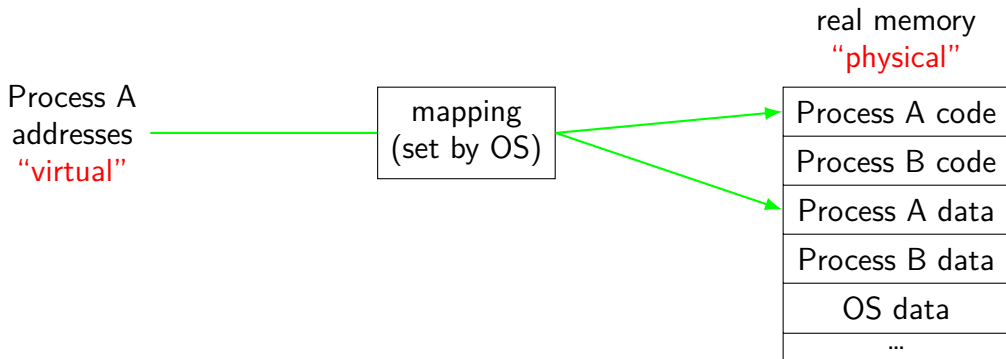

program addresses are 'virtual'
real addresses are 'physical'
can be **different sizes!**

address translation

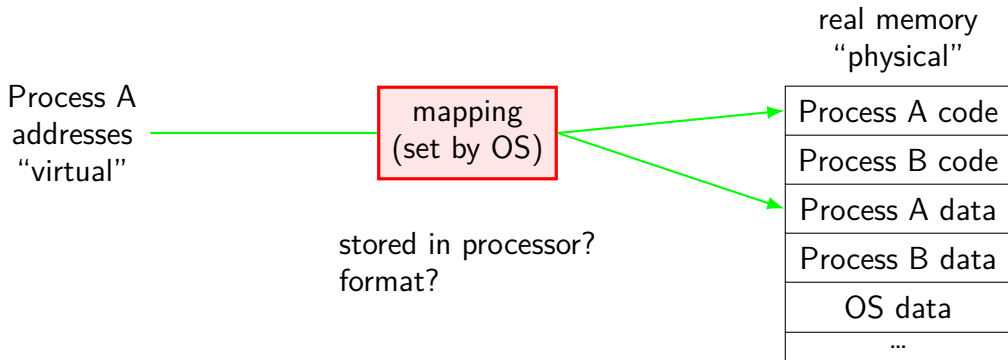

toy program memory

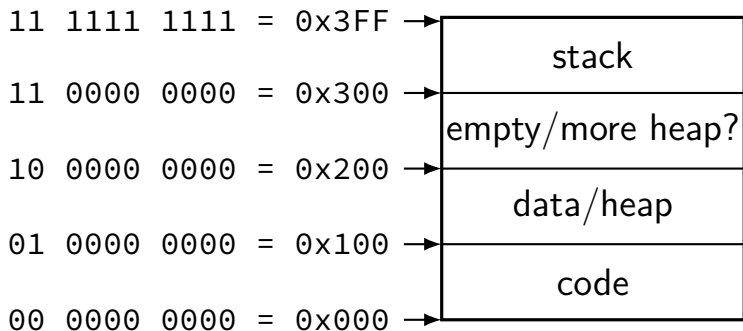

toy program memory

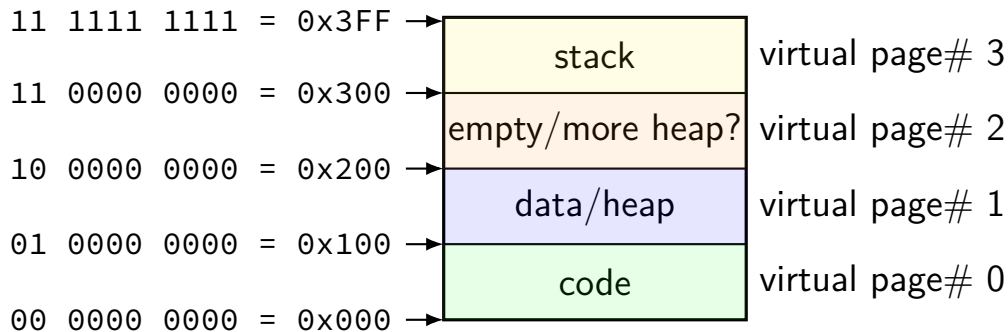

toy program memory

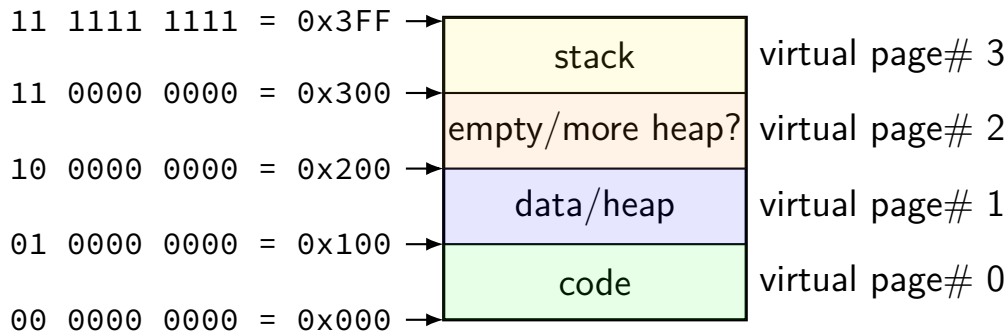

divide memory into **pages** (2^8 bytes in this case)
“virtual” = addresses the program sees

toy program memory

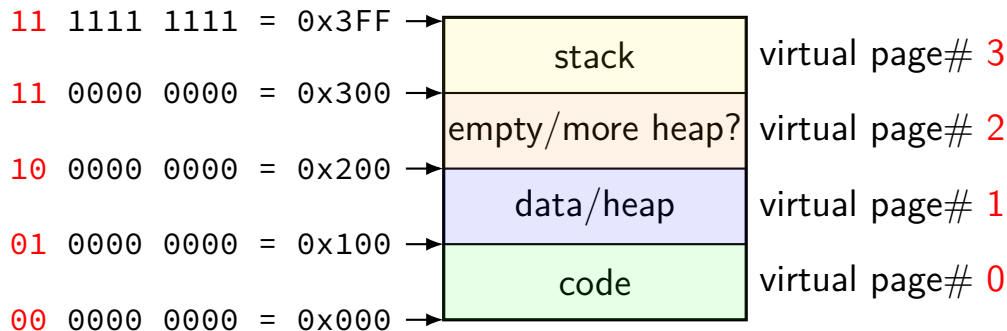

page number is upper bits of address
(because page size is power of two)

toy program memory

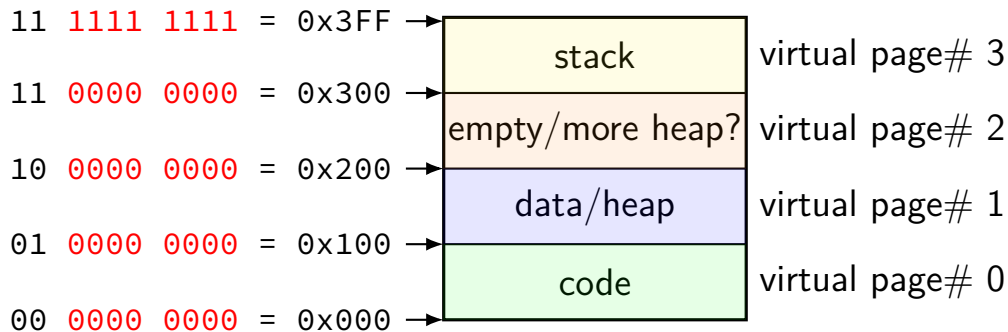

rest of address is called **page offset**

toy physical memory

program memory
virtual addresses

11 0000 0000 to 11 1111 1111
10 0000 0000 to 10 1111 1111
01 0000 0000 to 01 1111 1111
00 0000 0000 to 00 1111 1111

real memory
physical addresses

111 0000 0000 to 111 1111 1111
001 0000 0000 to 001 1111 1111
000 0000 0000 to 000 1111 1111

toy physical memory

program memory
virtual addresses

11	0000	0000	to
11	1111	1111	
10	0000	0000	to
10	1111	1111	
01	0000	0000	to
01	1111	1111	
00	0000	0000	to
00	1111	1111	

real memory
physical addresses

111	0000	0000	to
111	1111	1111	
001	0000	0000	to
001	1111	1111	
000	0000	0000	to
000	1111	1111	

physical page 7

physical page 1

physical page 0

toy physical memory

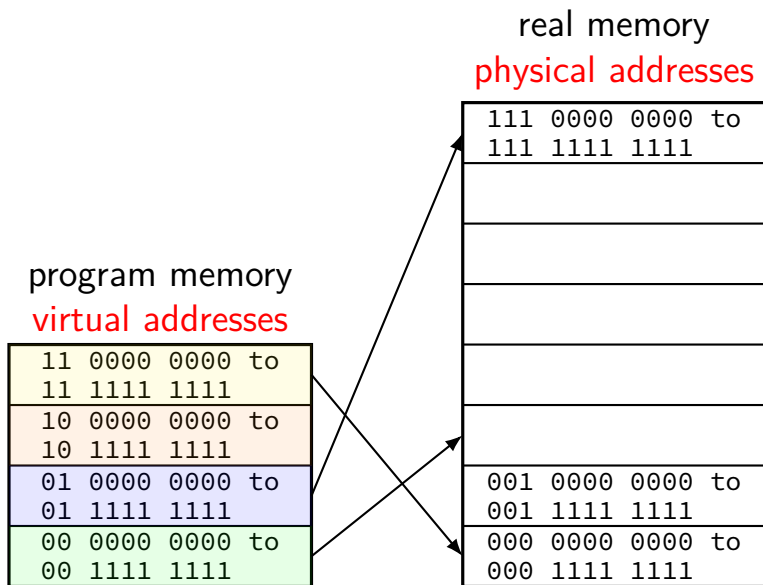

toy physical memory

virtual page #	physical page #
00	010 (2)
01	111 (7)
10	<i>none</i>
11	000 (0)

program memory
virtual addresses

11 0000 0000 to 11 1111 1111
10 0000 0000 to 10 1111 1111
01 0000 0000 to 01 1111 1111
00 0000 0000 to 00 1111 1111

real memory
physical addresses

111 0000 0000 to 111 1111 1111
001 0000 0000 to 001 1111 1111
000 0000 0000 to 000 1111 1111

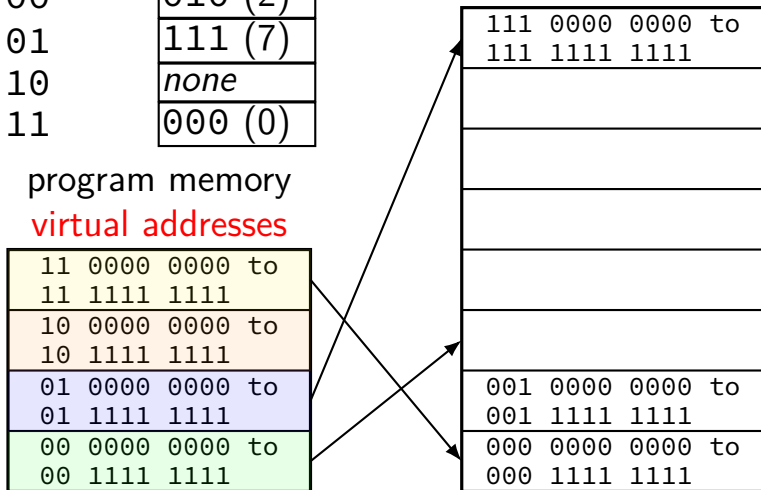

toy physical memory

page table!

virtual page #	physical page #
00	010 (2)
01	111 (7)
10	none
11	000 (0)

program memory
virtual addresses

11 0000 0000 to 11 1111 1111
10 0000 0000 to 10 1111 1111
01 0000 0000 to 01 1111 1111
00 0000 0000 to 00 1111 1111

real memory
physical addresses

111 0000 0000 to 111 1111 1111
001 0000 0000 to 001 1111 1111
000 0000 0000 to 000 1111 1111

toy page table lookup

virtual page #	valid?	physical page #
00	1	010 (2, code)
01	1	111 (7, data)
10	0	??? (ignored)
11	1	000 (0, stack)

toy page table lookup

01 1101 0010 — address from CPU

virtual
page # valid? physical page #

00	1	010 (2, code)
01	1	111 (7, data)
10	0	??? (ignored)
11	1	000 (0, stack)

trigger exception if 0?

to cache (data or instruction)

toy page table lookup

01 1101 0010 — address from CPU

virtual
page # valid? physical page #

00	1	010 (2, code)
01	1	111 (7, data)
10	0	??? (ignored)
11	1	000 (0, stack)

“page
table
entry”

111 1101 0010

trigger exception if 0?

to cache (data or instruction)

“virtual page number” lookup

01 1101 0010 — address from CPU

virtual
page # valid? physical page #

00	1	010 (2, code)
01	1	111 (7, data)
10	0	??? (ignored)
11	1	000 (0, stack)

111 1101 0010

trigger exception if 0?

to cache (data or instruction)

toy page table lookup

01 1101 0010 — address from CPU

virtual
page # valid? physical page #

00	1	010 (2, code)
01	1	111 (7, data)
10	0	??? (ignored)
11	1	000 (0, stack)

“physical page number”

111 1101 0010

trigger exception if 0?

to cache (data or instruction)

toy pa, “page offset” oookup

01 1101 0010 — address from CPU

virtual
page # valid? physical page #

00	1	010 (2, code)
01	1	111 (7, data)
10	0	??? (ignored)
11	1	000 (0, stack)

“page offset”

111 1101 0010

trigger exception if 0?

to cache (data or instruction)

switching page tables

part of context switch is changing the page table

extra **privileged instructions**

switching page tables

part of context switch is changing the page table

extra **privileged instructions**

where in memory is the code that does this switching?

switching page tables

part of context switch is changing the page table

extra **privileged instructions**

where in memory is the code that does this switching?

probably have a page table entry pointing to it
hopefully marked kernel-mode-only

switching page tables

part of context switch is changing the page table

extra **privileged instructions**

where in memory is the code that does this switching?

probably have a page table entry pointing to it
hopefully marked kernel-mode-only

code better not be modified by user program

otherwise: uncontrolled way to “escape” user mode

kernel-mode only

virtual page #	valid?	physical page #	kernel only?
00	1	010 (2, code)	0
01	1	111 (7, data)	0
10	1	000 (0, stack)	0
11	1	001 (1, OS)	1

kernel-mode only

01 1101 0010 — address from CPU

virtual page #	valid?	physical page #	kernel only?
00	1	010 (2, code)	0
01	1	111 (7, data)	0
10	1	000 (0, stack)	0
11	1	001 (1, OS)	1

trigger exception if 0?

trigger exception if 1 and in user mode?

111 1101 0010

to cache

kernel-mode only

01 1101 0010 — address from CPU

virtual page #	valid?	physical page #	kernel only?
00	1	010 (2, code)	0
01	1	111 (7, data)	0
10	1	000 (0, stack)	0
11	1	001 (1, OS)	1

trigger exception if 0?

trigger exception if 1 and in user mode?

111 1101 0010

to cache

kernel-mode only

01 1101 0010 — address from CPU

virtual page #	valid?	physical page #	kernel only?
00	1	010 (2, code)	0
01	1	111 (7, data)	0
10	1	000 (0, stack)	0
11	1	001 (1, OS)	1

trigger exception if 0?

trigger exception if 1 and in user mode?

111 1101 0010

to cache

kernel-mode only

01 1101 0010 — address from CPU

virtual page #	valid?	physical page #	kernel only?
00	1	010 (2, code)	0
01	1	111 (7, data)	0
10	1	000 (0, stack)	0
11	1	001 (1, OS)	1

trigger exception if 0?

trigger exception if 1 and in user mode?

111 1101 0010

to cache

kernel-mode only

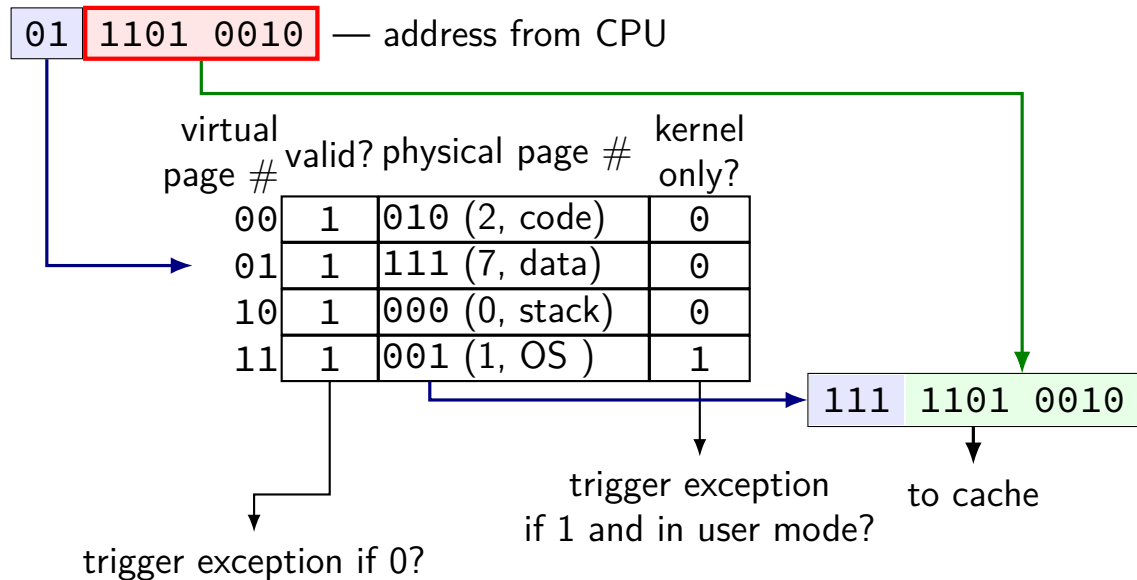

on virtual address sizes

virtual address size = size of pointer?

often, but — sometimes part of pointer not used

example: typical x86-64 only use 48 bits

rest of bits have fixed value

virtual address size is amount used for mapping

address space sizes

amount of stuff that can be addressed = address space size
based on number of unique addresses

e.g. 32-bit virtual address = 2^{32} byte virtual address space

e.g. 20-bit physical address = 2^{20} byte physical address space

address space sizes

amount of stuff that can be addressed = address space size
based on number of unique addresses

e.g. 32-bit virtual address = 2^{32} byte virtual address space

e.g. 20-bit physical address = 2^{20} byte physical address space

what if my machine has 3GB of memory (not power of two)?

not all addresses in physical address space are useful

most common situation (since CPUs support having a lot of memory)

exercise: page counting

suppose 32-bit virtual (program) addresses

and each page is 4096 bytes (2^{12} bytes)

how many virtual pages?

exercise: page counting

suppose 32-bit virtual (program) addresses

and each page is 4096 bytes (2^{12} bytes)

how many virtual pages?

$$2^{32} / 2^{12} = 2^{20}$$

exercise: page table size

suppose 32-bit virtual (program) addresses

suppose 30-bit physical (hardware) addresses

each page is 4096 bytes (2^{12} bytes)

page table entries have physical page #, valid bit, kernel-mode bit

how big is the page table (if laid out like ones we've seen)?

exercise: page table size

suppose 32-bit virtual (program) addresses

suppose 30-bit physical (hardware) addresses

each page is 4096 bytes (2^{12} bytes)

page table entries have physical page #, valid bit, kernel-mode bit

how big is the page table (if laid out like ones we've seen)?

2^{20} entries \times (18 + 2) bits per entry

issue: where can we store that?

exercise: address splitting

and each page is 4096 bytes (2^{12} bytes)

split the address `0x12345678` into page number and page offset:

exercise: address splitting

and each page is 4096 bytes (2^{12} bytes)

split the address 0x12345678 into page number and page offset:

page #: 0x12345; offset: 0x678

page tables in memory

where can processor store megabytes of page tables? **in memory**

page table entry layout

valid (bit 15)	kernel (bit 14)	physical page # (bits 4–13)	unused (bit 0-3)
----------------	-----------------	-----------------------------	------------------

page tables in memory

where can processor store megabytes of page tables? **in memory**

page table entry layout

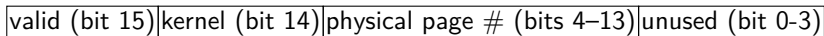

page table base register

0x00010000



page tables in memory

where can processor store megabytes of page tables? **in memory**

page table entry layout

valid (bit 15)	kernel (bit 14)	physical page # (bits 4–13)	unused (bit 0-3)
----------------	-----------------	-----------------------------	------------------

page table base register

0x00010000



physical memory

addresses	bytes
0x00000000-1	00000000 00000000
...	...
0x00010000-1	00000000 00000000
0x00010002-3	10100010 01100000
0x00010004-5	10000010 11000000
0x00010006-7	10110000 00110000
...	...
0x000101FE-F	10001110 10000000
0x00010200-1	10100010 00111010

page tables in memory

where can processor store megabytes of page tables? **in memory**

page table entry layout

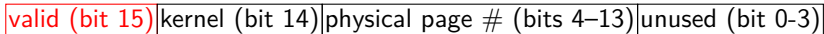

page table base register

0x00010000



physical memory

addresses	bytes
0x00000000-1	00000000 00000000
...	...
0x00010000-1	00000000 00000000
0x00010002-3	10100010 01100000
0x00010004-5	10000010 11000000
0x00010006-7	10110000 00110000
...	...
0x000101FE-F	10001110 10000000
0x00010200-1	10100010 00111010

page tables in memory

where can processor store megabytes of page tables? **in memory**

page table entry layout

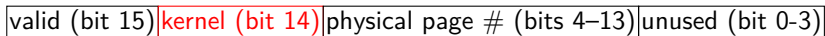

page table base register

0x00010000



physical memory

addresses	bytes
0x00000000-1	00000000 00000000
...	...
0x00010000-1	00000000 00000000
0x00010002-3	10100010 01100000
0x00010004-5	10000010 11000000
0x00010006-7	10110000 00110000
...	...
0x000101FE-F	10001110 10000000
0x00010200-1	10100010 00111010

page tables in memory

where can processor store megabytes of page tables? **in memory**

page table entry layout



page table base register

0x00010000



physical memory

addresses	bytes
0x00000000-1	00000000 00000000
...	...
0x00010000-1	00000000 00000000
0x00010002-3	10100010 01100000
0x00010004-5	10000010 11000000
0x00010006-7	10110000 00110000
...	...
0x000101FE-F	10001110 10000000
0x00010200-1	10100010 00111010

page tables in memory

where can processor store megabytes of page tables? **in memory**

page table entry layout

valid (bit 15)	kernel (bit 14)	physical page # (bits 4–13)	unused (bit 0-3)
----------------	-----------------	-----------------------------	------------------

page table base register

0x00010000

page table (logically)

virtual page #	valid?	kernel?	physical page #
0000 0000	0	0	00 0000 0000
0000 0001	1	0	10 0010 0110
0000 0010	1	0	00 0000 1100
0000 0011	1	0	11 0000 0011
...			
1111 1111	1	0	00 1110 1000

physical memory

addresses	bytes
0x00000000-1	00000000 00000000
...	
0x00010000-1	00000000 00000000
0x00010002-3	10100010 01100000
0x00010004-5	10000010 11000000
0x00010006-7	10110000 00110000
...	
0x000101FE-F	10001110 10000000
0x00010200-1	10100010 00111010

page tables in memory

where can processor store megabytes of page tables? **in memory**

page table entry layout

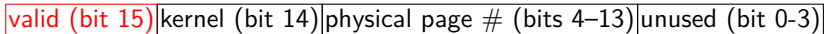

page table base register

0x00010000

page table (logically)

virtual page #	valid?	kernel?	physical page #
0000 0000	0	0	00 0000 0000
0000 0001	1	0	10 0010 0110
0000 0010	1	0	00 0000 1100
0000 0011	1	0	11 0000 0011
...			
1111 1111	1	0	00 1110 1000

physical memory

addresses	bytes
0x00000000-1	00000000 00000000
...	
0x00010000-1	00000000 00000000
0x00010002-3	10100010 01100000
0x00010004-5	10000010 11000000
0x00010006-7	10110000 00110000
...	
0x000101FE-F	10001110 10000000
0x00010200-1	10100010 00111010

page tables in memory

where can processor store megabytes of page tables? **in memory**

page table entry layout



page table base register

0x00010000

page table (logically)

virtual page #	valid?	kernel?	physical page #
0000 0000	0	0	00 0000 0000
0000 0001	1	0	10 0010 0110
0000 0010	1	0	00 0000 1100
0000 0011	1	0	11 0000 0011
...			
1111 1111	1	0	00 1110 1000

physical memory

addresses	bytes
0x00000000-1	00000000 00000000
...	
0x00010000-1	00000000 00000000
0x00010002-3	10100010 01100000
0x00010004-5	10000010 11000000
0x00010006-7	10110000 00110000
...	
0x000101FE-F	10001110 10000000
0x00010200-1	10100010 00111010

page tables in memory

where can processor store megabytes of page tables? **in memory**

page table entry layout

valid (bit 15)	kernel (bit 14)	physical page # (bits 4–13)	unused (bit 0-3)
----------------	-----------------	-----------------------------	------------------

page table base register

0x00010000

page table (logically)

virtual page #	valid?	kernel?	physical page #
0000 0000	0	0	00 0000 0000
0000 0001	1	0	10 0010 0110
0000 0010	1	0	00 0000 1100
0000 0011	1	0	11 0000 0011
...			
1111 1111	1	0	00 1110 1000

physical memory

addresses	bytes
0x00000000-1	00000000 00000000
...	
0x00010000-1	00000000 00000000
0x00010002-3	10100010 01100000
0x00010004-5	10000010 11000000
0x00010006-7	10110000 00110000
...	
0x000101FE-F	10001110 10000000
0x00010200-1	10100010 00111010

memory access with page table

virtual address

11	0101	01	00	1101	1111
----	------	----	----	------	------

memory access with page table

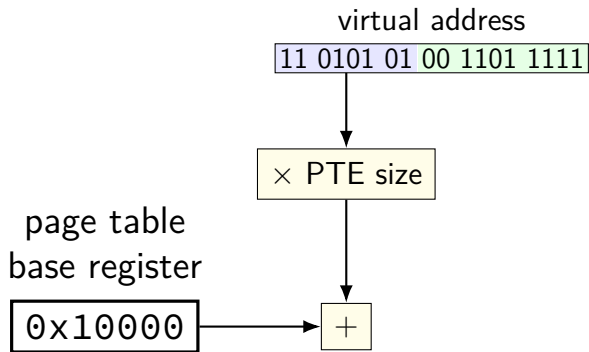

memory access with page table

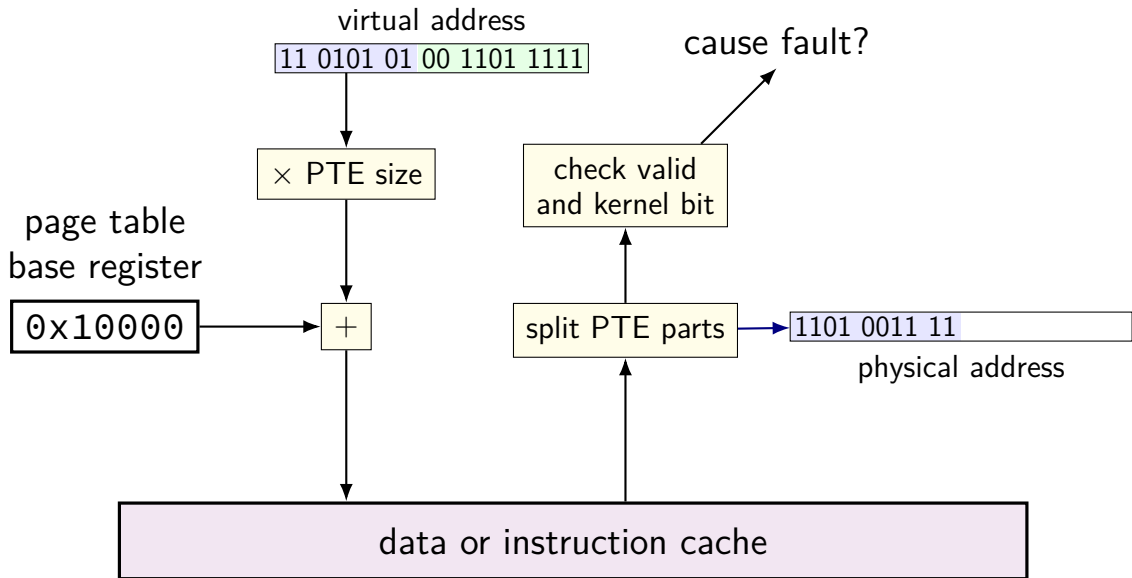

memory access with page table

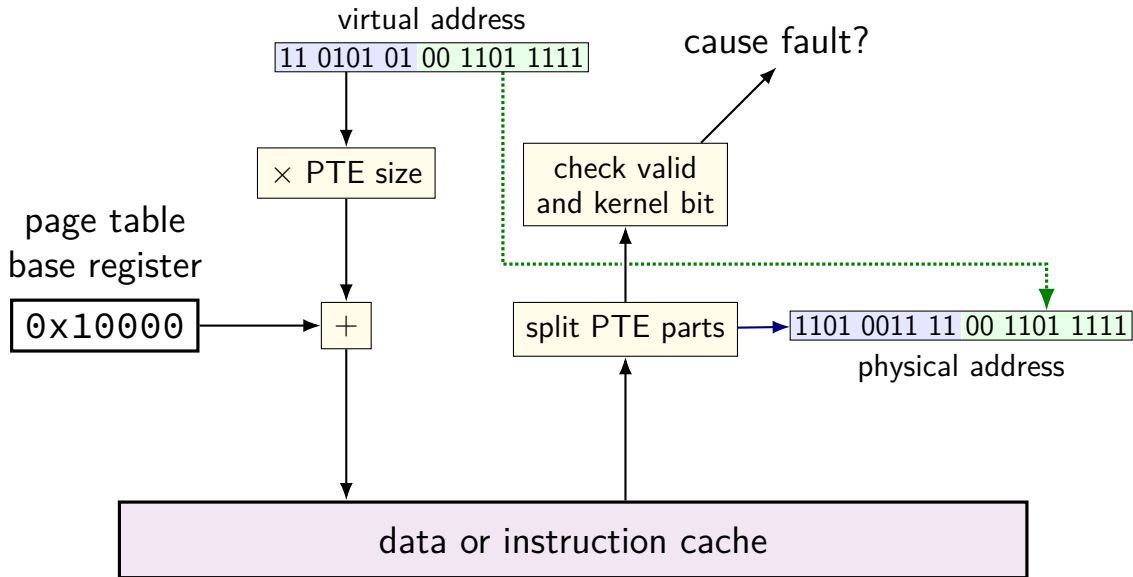

memory access with page table

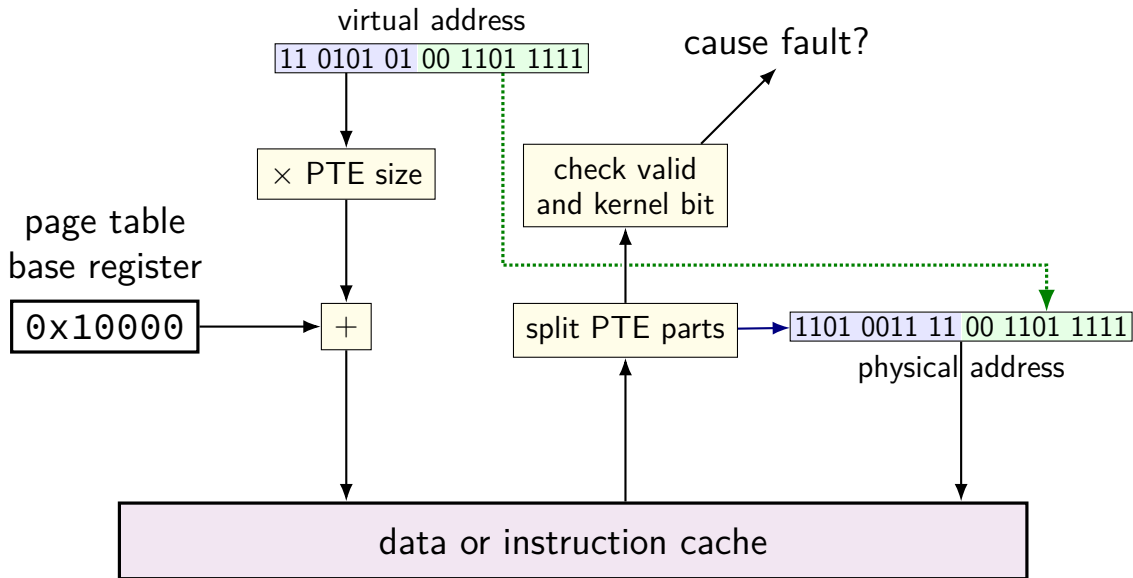

memory access with page table

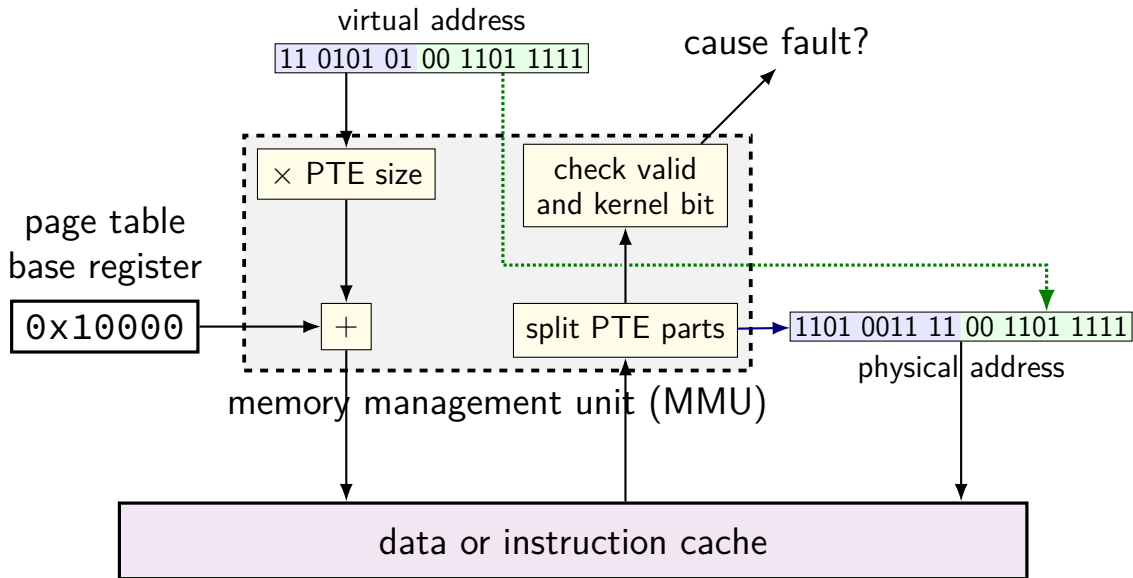

memory access with page table

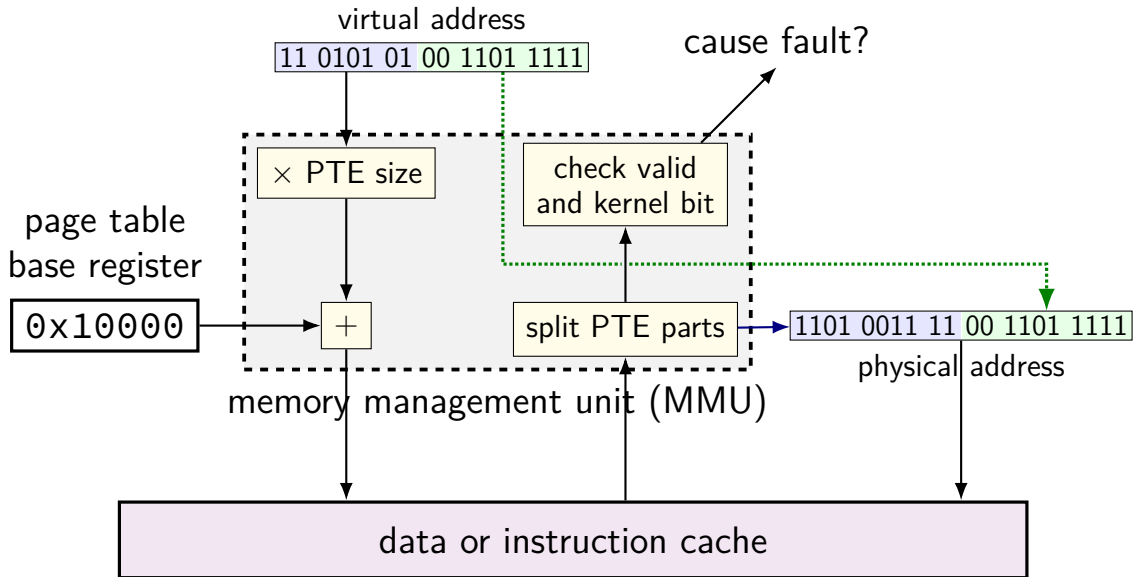

MMUs in the pipeline

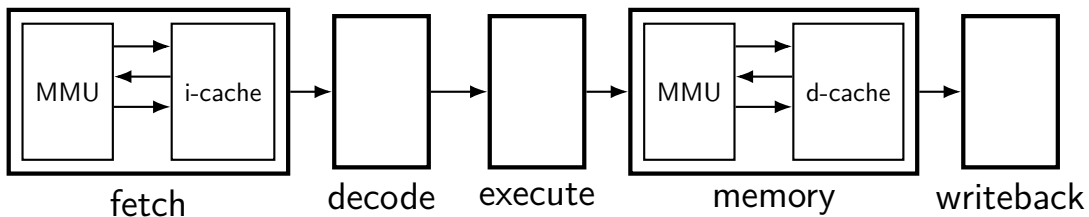

up to four memory accesses per instruction

MMUs in the pipeline

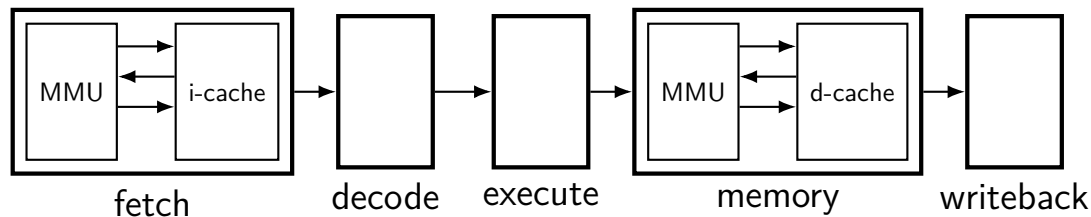

up to four memory accesses per instruction

challenging to make this fast (topic for a future date)

exercise: 64-bit system

my desktop: 39-bit physical addresses; 48-bit virtual addresses

4096 byte pages

exercise: 64-bit system

my desktop: 39-bit physical addresses; 48-bit virtual addresses

4096 byte pages

top 16 bits of address not used for translation

exercise: 64-bit system

my desktop: 39-bit physical addresses; 48-bit virtual addresses

4096 byte pages

exercise: how many page table entries?

exercise: how large are physical page numbers?

exercise: 64-bit system

my desktop: 39-bit physical addresses; 48-bit virtual addresses

4096 byte pages

exercise: how many page table entries? $2^{48}/2^{12} = 2^{36}$ entries

exercise: how large are physical page numbers? $39 - 12 = 27$ bits

exercise: 64-bit system

my desktop: 39-bit physical addresses; 48-bit virtual addresses

4096 byte pages

exercise: how many page table entries? $2^{48}/2^{12} = 2^{36}$ entries

exercise: how large are physical page numbers? $39 - 12 = 27$ bits

page table entries are 8 bytes (room for expansion, metadata)

trick: power of two size makes table lookup faster

would take up 2^{39} bytes?? (512GB??)

two big problems to solve later

two **extra cache accesses** seems really slow

solution: more caches (called “TLB”, topic for later weeks)

page tables seem **really huge**

solution: not just a flat table

exercise setup

5-bit virtual addresses, 6-bit physical addresses, 8-byte pages

page table

virtual page #	valid?	physical page #
00	1	010
01	1	111
10	0	000
11	1	000

physical addresses	bytes
0x00-3	00 11 22 33
0x04-7	44 55 66 77
0x08-B	88 99 AA BB
0x0C-F	CC DD EE FF
0x10-3	1A 2A 3A 4A
0x14-7	1B 2B 3B 4B
0x18-B	1C 2C 3C 4C
0x1C-F	1C 2C 3C 4C

physical addresses	bytes
0x20-3	D0 D1 D2 D3
0x24-7	D4 D5 D6 D7
0x28-B	89 9A AB BC
0x2C-F	CD DE EF F0
0x30-3	BA 0A BA 0A
0x34-7	CB 0B CB 0B
0x38-B	DC 0C DC 0C
0x3C-F	EC 0C EC 0C

exercise setup

5-bit virtual addresses, 6-bit physical addresses, 8-byte pages

page table

virtual page #	valid?	physical page #
00	1	010
01	1	111
10	0	000
11	1	000

physical addresses	bytes
0x00-3	00 11 22 33
0x04-7	44 55 66 77
0x08-B	88 99 AA BB
0x0C-F	CC DD EE FF
0x10-3	1A 2A 3A 4A
0x14-7	1B 2B 3B 4B
0x18-B	1C 2C 3C 4C
0x1C-F	1C 2C 3C 4C

physical addresses	bytes
0x20-3	D0 D1 D2 D3
0x24-7	D4 D5 D6 D7
0x28-B	EA AB BC
0x2C-F	CE EF F0
0x30-3	BA 0A BA 0A
0x34-7	CB 0B CB 0B
0x38-B	DC 0C DC 0C
0x3C-F	EC 0C EC 0C

phys. page 0

phys. page 1

exercise

5-bit virtual addresses, 6-bit physical addresses, 8-byte pages

(virtual addresses) $0x18 = ???$; $0x03 = ???$; $0x0A = ???$; $0x13 = ???$

page table

virtual page #	valid?	physical page #
00	1	010
01	1	111
10	0	000
11	1	000

physical addresses	bytes
$0x00-3$	00 11 22 33
$0x04-7$	44 55 66 77
$0x08-B$	88 99 AA BB
$0x0C-F$	CC DD EE FF
$0x10-3$	1A 2A 3A 4A
$0x14-7$	1B 2B 3B 4B
$0x18-B$	1C 2C 3C 4C
$0x1C-F$	1C 2C 3C 4C

physical addresses	bytes
$0x20-3$	D0 D1 D2 D3
$0x24-7$	D4 D5 D6 D7
$0x28-B$	89 9A AB BC
$0x2C-F$	CD DE EF F0
$0x30-3$	BA 0A BA 0A
$0x34-7$	CB 0B CB 0B
$0x38-B$	DC 0C DC 0C
$0x3C-F$	EC 0C EC 0C

exercise

5-bit virtual addresses, 6-bit physical addresses, 8-byte pages

(virtual addresses) $0x18 = 00$; $0x03 = ???$; $0x0A = ???$; $0x13 = ???$

page table

virtual page #	valid?	physical page #
00	1	010
01	1	111
10	0	000
11	1	000

physical addresses	bytes
$0x00-3$	00 11 22 33
$0x04-7$	44 55 66 77
$0x08-B$	88 99 AA BB
$0x0C-F$	CC DD EE FF
$0x10-3$	1A 2A 3A 4A
$0x14-7$	1B 2B 3B 4B
$0x18-B$	1C 2C 3C 4C
$0x1C-F$	1C 2C 3C 4C

physical addresses	bytes
$0x20-3$	D0 D1 D2 D3
$0x24-7$	D4 D5 D6 D7
$0x28-B$	89 9A AB BC
$0x2C-F$	CD DE EF F0
$0x30-3$	BA 0A BA 0A
$0x34-7$	CB 0B CB 0B
$0x38-B$	DC 0C DC 0C
$0x3C-F$	EC 0C EC 0C

exercise

5-bit virtual addresses, 6-bit physical addresses, 8-byte pages

(virtual addresses) $0x18 = 00$; $0x03 = 0x4A$; $0x0A = ???$; $0x13 = ???$

page table

virtual page #	valid?	physical page #
00	1	010
01	1	111
10	0	000
11	1	000

physical addresses	bytes
$0x00-3$	00 11 22 33
$0x04-7$	44 55 66 77
$0x08-B$	88 99 AA BB
$0x0C-F$	CC DD EE FF
$0x10-3$	1A 2A 3A 4A
$0x14-7$	1B 2B 3B 4B
$0x18-B$	1C 2C 3C 4C
$0x1C-F$	1C 2C 3C 4C

physical addresses	bytes
$0x20-3$	D0 D1 D2 D3
$0x24-7$	D4 D5 D6 D7
$0x28-B$	89 9A AB BC
$0x2C-F$	CD DE EF F0
$0x30-3$	BA 0A BA 0A
$0x34-7$	CB 0B CB 0B
$0x38-B$	DC 0C DC 0C
$0x3C-F$	EC 0C EC 0C

exercise

5-bit virtual addresses, 6-bit physical addresses, 8-byte pages

(virtual addresses) $0x18 = 00$; $0x03 = 0x4A$; $0x0A = 0xDC$; $0x13 = ???$

page table

virtual page #	valid?	physical page #
00	1	010
01	1	111
10	0	000
11	1	000

physical addresses	bytes
$0x00-3$	00 11 22 33
$0x04-7$	44 55 66 77
$0x08-B$	88 99 AA BB
$0x0C-F$	CC DD EE FF
$0x10-3$	1A 2A 3A 4A
$0x14-7$	1B 2B 3B 4B
$0x18-B$	1C 2C 3C 4C
$0x1C-F$	1C 2C 3C 4C

physical addresses	bytes
$0x20-3$	D0 D1 D2 D3
$0x24-7$	D4 D5 D6 D7
$0x28-B$	89 9A AB BC
$0x2C-F$	CD DE EF F0
$0x30-3$	BA 0A BA 0A
$0x34-7$	CB 0B CB 0B
$0x38-B$	DC 0C DC 0C
$0x3C-F$	EC 0C EC 0C

exercise

5-bit virtual addresses, 6-bit physical addresses, 8-byte pages

(virtual addresses) $0x18 = 00$; $0x03 = 0x4A$; $0x0A = 0xDC$; $0x13 = \text{fault}$

page table

virtual page #	valid?	physical page #
00	1	010
01	1	111
10	0	000
11	1	000

physical addresses	bytes
$0x00-3$	00 11 22 33
$0x04-7$	44 55 66 77
$0x08-B$	88 99 AA BB
$0x0C-F$	CC DD EE FF
$0x10-3$	1A 2A 3A 4A
$0x14-7$	1B 2B 3B 4B
$0x18-B$	1C 2C 3C 4C
$0x1C-F$	1C 2C 3C 4C

physical addresses	bytes
$0x20-3$	D0 D1 D2 D3
$0x24-7$	D4 D5 D6 D7
$0x28-B$	89 9A AB BC
$0x2C-F$	CD DE EF F0
$0x30-3$	BA 0A BA 0A
$0x34-7$	CB 0B CB 0B
$0x38-B$	DC 0C DC 0C
$0x3C-F$	EC 0C EC 0C

emacs (two copies)

Emacs (run by user mst3k)

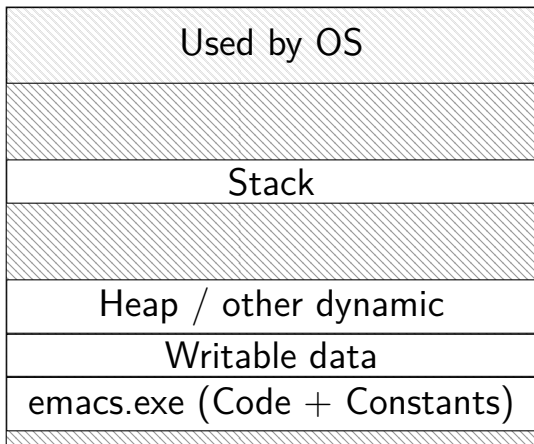

Emacs (run by user xyz4w)

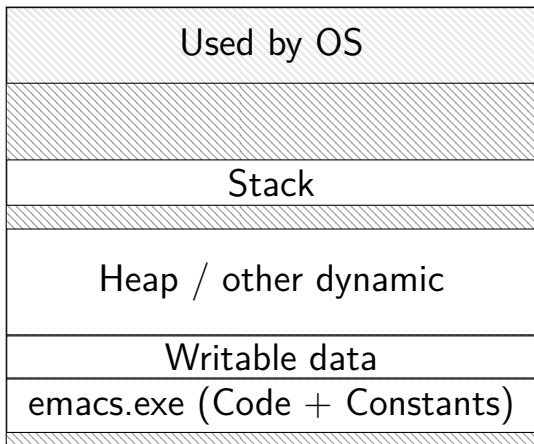

emacs (two copies)

Emacs (run by user mst3k)

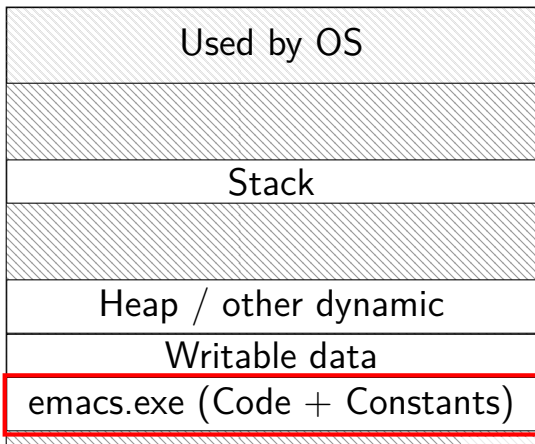

Emacs (run by user xyz4w)

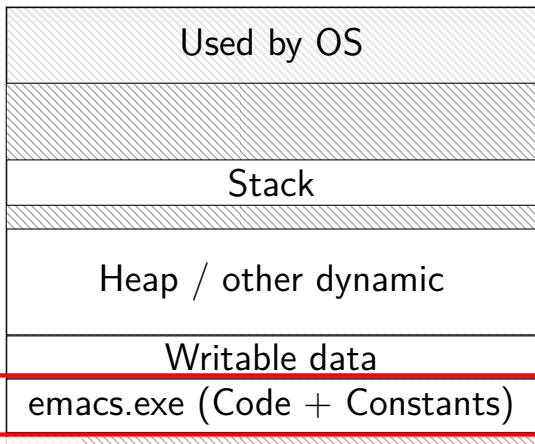

same data?

two copies of program

would like to only have one copy of program

what if mst3k's emacs tries to modify its code?

would break process abstraction:

“illusion of own memory”

typical page table entries

solution: same idea as kernel-only bit

page table entry will have more **permissions bits**

can read?

can write?

can execute?

checked by MMU like valid/kernel bit

page table (logically)

virtual page #	valid?	kernel?	write?	exec?	physical page #
0000 0000	0	0	0	0	00 0000 0000
0000 0001	1	0	1	0	10 0010 0110
0000 0010	1	0	1	0	00 0000 1100
0000 0011	1	0	0	1	11 0000 0011
...					
1111 1111	1	0	1	0	00 1110 1000

shared libraries

C standard library has lots of common code:

```
printf  
fopen  
qsort  
...
```

would like to not have multiple copies

solution: multiple virtual read-only copies, one physical copy

efficient shared libraries

recall: linking

- placeholders to fill in with addresses

- need to change depending on **where library ends up?**

different code depending on where library ends up?

one solution: **position-independent code**

page tables

program memory = virtual; real memory = physical

each memory divided into fixed-sizes **pages**

each virtual page has a **page table entry**:

- has location of physical page (if any)

- has valid bit

- has permission bits

all page table entries stored in page table

permission or validity error triggers **exception**

page table tricks

page tables let operating systems do 'magic' with memory

key idea: OS doesn't need to crash on a fault!

instead: change page tables and rerun memory access
similar idea to trap-and-emulate

space on demand

Program Memory

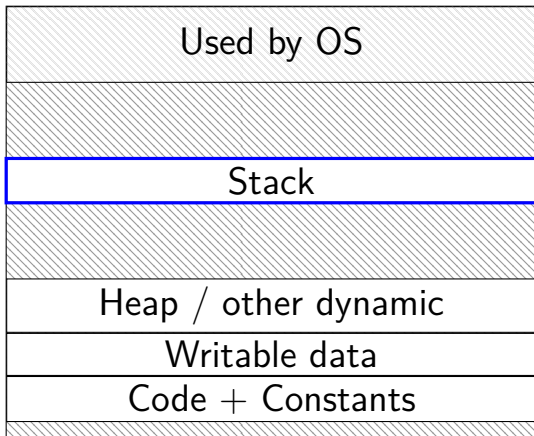

space on demand

Program Memory

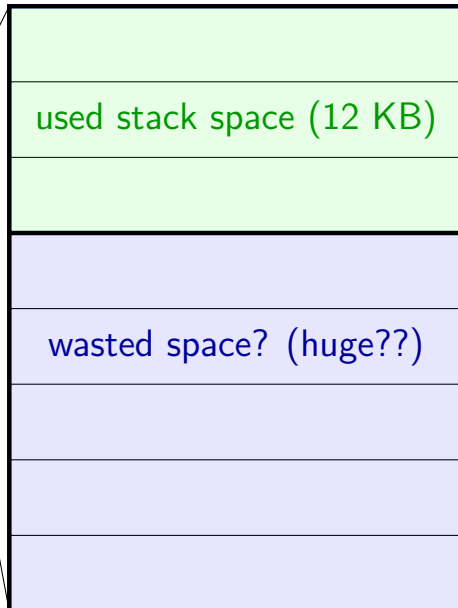
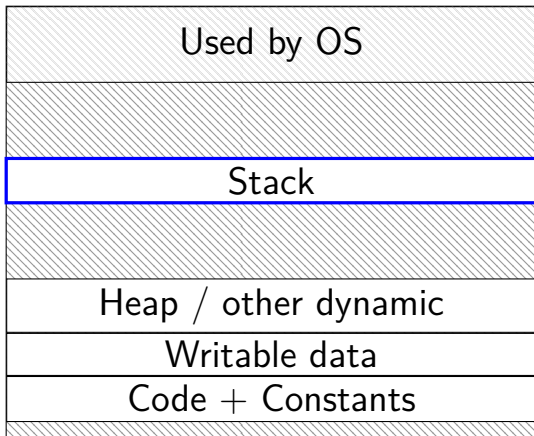

space on demand

Program Memory

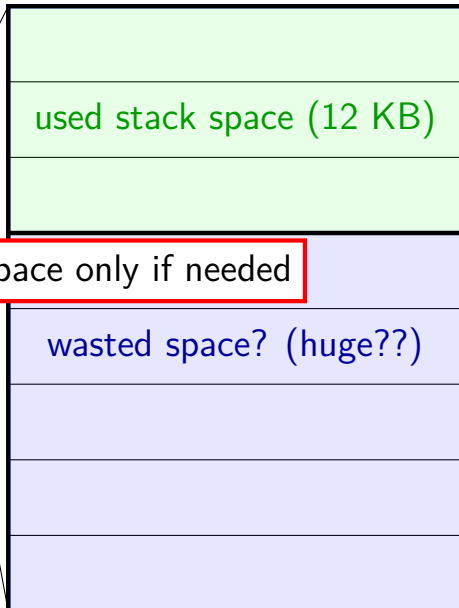
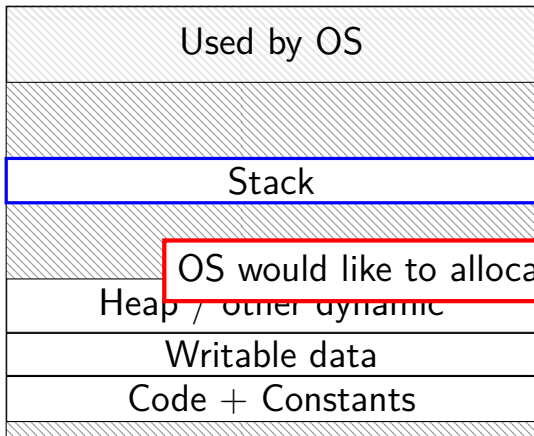

OS would like to allocate space only if needed

allocating space on demand

`%rsp = 0x7FFFC000`

```
...  
// requires more stack space  
A: pushq %rbx  
  
B: movq 8(%rcx), %rbx  
C: addq %rbx, %rax  
...
```

VPN

```
...  
0x7FFFB  
0x7FFFC  
0x7FFFD  
0x7FFFE  
0x7FFFF  
...
```

valid? physical
page

valid?	physical page
...	...
0	---
1	0x200DF
1	0x12340
1	0x12347
1	0x12345
...	...

allocating space on demand

`%rsp = 0x7FFFC000`

```
...  
// requires more stack space  
A: pushq %rbx  
B: movq 8(%rcx), %rbx  
C: addq %rbx, %rax  
...
```

→ page fault!

VPN

```
...  
0x7FFFB  
0x7FFFC  
0x7FFFD  
0x7FFFE  
0x7FFFF  
...
```

valid? physical
page

valid?	physical page
...	...
0	---
1	0x200DF
1	0x12340
1	0x12347
1	0x12345
...	...

pushq triggers exception
hardware says “accessing address 0x7FFFBFF8”
OS looks up what’s should be there — “stack”

allocating space on demand

`%rsp = 0x7FFFC000`

```
...  
// requires more stack space  
A: pushq %rbx restarted  
B: movq 8(%rcx), %rbx  
C: addq %rbx, %rax  
...
```

VPN	valid?	physical page
...
<code>0x7FFFB</code>	<code>1</code>	<code>0x200D8</code>
<code>0x7FFFC</code>	<code>1</code>	<code>0x200DF</code>
<code>0x7FFFD</code>	<code>1</code>	<code>0x12340</code>
<code>0x7FFFE</code>	<code>1</code>	<code>0x12347</code>
<code>0x7FFFF</code>	<code>1</code>	<code>0x12345</code>
...

in exception handler, OS allocates more stack space
OS updates the page table
then returns to retry the instruction

allocating space on demand

note: the space doesn't have to be initially empty

only change: load from file, etc. instead of allocating empty page

loading program can be **merely creating empty page table**

everything else can be handled **in response to page faults**

no time/space spent loading/allocating unneeded space

backup slides